

APPLICATIONS

DC voltage filtering for:

- DC link
- Resonant filtering
- Active correction (*FACTS*)
- HVDC
- High Power DC Supply

PACKAGING

Rectangular stainless steel case.
Grounding is via a nut on top of the case.

PRESENTATION

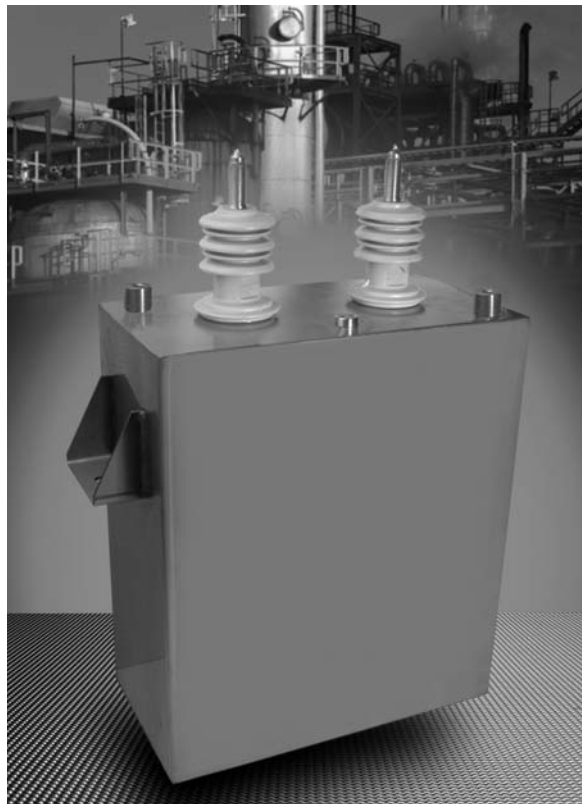

ELECTRICAL CHARACTERISTICS

Capacitance range C_n	2.6 μ F to 612 μ F
Tolerance on C_n	$\pm 10\%$
Nominal DC voltage range	6500V to 56kV (up to 100kV on specific design)
Operating hot-spot temperature range	-55°C to 85°C
Lifetime @ V_n and 70°C hot-spot temperature	100,000 hours
Test voltage between terminals	1.5 V_n during 10s
Test voltage between shorten terminals and case	1.5 V_n during 10s

Table of Values

Height millimeters (inches)	$V_n = 6500V$ Terminal Type A Base 350x185 (Length x Width)			$V_n = 7900V$ Terminal Type A Base 350x185 (Length x Width)		
	C (μF)	Rs ($m\Omega$)	Part Number	C (μF)	Rs ($m\Omega$)	Part Number
315 (12.40)	188	3.4	DLIFMXAXA1886	126	3.6	DLIFMXAXB1266
410 (16.14)	275	3.3	DLIFMXAXA2756	184	3.4	DLIFMXAXB1846
500 (19.69)	362	3.2	DLIFMXAXA3626	242	3.3	DLIFMXAXB2426
595 (23.43)	450	3.2	DLIFMXAXA0457	300	3.2	DLIFMXAXB0307
685 (26.97)	537	3.1	DLIFMXAXA5376	359	3.2	DLIFMXAXB3596
770 (30.31)	612	3.1	DLIFMXAXA6126	410	3.2	DLIFMXAXB0417

Height millimeters (inches)	$V_n = 9000V$ Terminal Type A Base 350x185 (Length x Width)			$V_n = 10500V$ Terminal Type A Base 350x185 (Length x Width)		
	C (μF)	Rs ($m\Omega$)	Part Number	C (μF)	Rs ($m\Omega$)	Part Number
315 (12.40)	95	3.7	DLIFMXAXC0956	73	5.8	DLIFMXAXD0736
410 (16.14)	138	3.4	DLIFMXAXC1386	107	5	DLIFMXAXD1076
500 (19.69)	181	3.3	DLIFMXAXC1816	140	4.6	DLIFMXAXD0147
595 (23.43)	225	3.3	DLIFMXAXC2256	174	4.4	DLIFMXAXD1746
685 (26.97)	269	3.2	DLIFMXAXC2696	208	4.3	DLIFMXAXD2086
770 (30.31)	307	3.2	DLIFMXAXC3076	237	4.3	DLIFMXAXD2376

Height millimeters (inches)	$V_n = 12000V$ Terminal Type A Base 350x185 (Length x Width)			$V_n = 14500V$ Terminal Type A Base 350x185 (Length x Width)		
	C (μF)	Rs ($m\Omega$)	Part Number	C (μF)	Rs ($m\Omega$)	Part Number
315 (12.40)	55	6.2	DLIFMXAXE0556	37.5	5.6	DLIFMXAXF3755
410 (16.14)	80	5.3	DLIFMXAXE0806	55	4.9	DLIFMXAXF0556
500 (19.69)	105	4.9	DLIFMXAXE1056	72	4.6	DLIFMXAXF0726
595 (23.43)	130	4.6	DLIFMXAXE0137	89	4.4	DLIFMXAXF0896
685 (26.97)	155	4.5	DLIFMXAXE1556	106	4.3	DLIFMXAXF1066
770 (30.31)	177	4.4	DLIFMXAXE1776	121	4.2	DLIFMXAXF1216

Height millimeters (inches)	$V_n = 15800V$ Terminal Type A Base 350x185 (Length x Width)			$V_n = 18000V$ Terminal Type B Base 350x185 (Length x Width)		
	C (μF)	Rs ($m\Omega$)	Part Number	C (μF)	Rs ($m\Omega$)	Part Number
315 (12.40)	31.5	5.9	DLIFMXAXG3155	19.5	7.8	DLIFMXBXH1955
410 (16.14)	46	5.1	DLIFMXAXG0466	30	6.5	DLIFMXBXH0306
500 (19.49)	60.5	4.7	DLIFMXAXG6055	45	5.9	DLIFMXBXH0456
595 (23.43)	75	4.5	DLIFMXAXG0756	51	5.6	DLIFMXBXH0516
685 (26.97)	89	4.4	DLIFMXAXG0896	62	5.4	DLIFMXBXH0626
770 (30.31)	102	4.3	DLIFMXAXG1026	72	5.3	DLIFMXBXH0726

Table of Values

Height millimeters (inches)	$V_n = 22000V$ Terminal Type B Base 520x185 (Length x Width)			$V_n = 26000V$ Terminal Type B Base 520x185 (Length x Width)		
	C (μF)	R_s (m Ω)	Part Number	C (μF)	R_s (m Ω)	Part Number
315 (12.40)	20	8.9	DLIFMXBXI0206	14.2	9.8	DLIFMXBXJ1425
410 (16.14)	31.5	7.2	DLIFMXBXI3155	22.5	7.8	DLIFMXBXJ2255
500 (19.69)	42.5	6.6	DLIFMXBXI4255	30	7	DLIFMXBXJ0306
595 (23.43)	54	6.2	DLIFMXBXI0546	38	6.6	DLIFMXBXJ0386
685 (26.97)	65	6	DLIFMXBXI0656	46	6.3	DLIFMXBXJ0466
770 (30.31)	75	5.9	DLIFMXBXI0756	53	6.2	DLIFMXBXJ0536

Height millimeters (inches)	$V_n = 28000V$ Terminal Type B Base 350x185 (Length x Width)			$V_n = 32000V$ Terminal Type B Base 695x185 (Length x Width)		
	C (μF)	R_s (m Ω)	Part Number	C (μF)	R_s (m Ω)	Part Number
315 (12.40)	5.8	6.8	DLIFMXBXK0585	12.8	11.2	DLIFMXBXL1285
410 (16.14)	9	5.9	DLIFMXBXK0905	20	8.8	DLIFMXBXL0206
500 (19.69)	12	5.5	DLIFMXBXK0126	27	7.9	DLIFMXBXL0276
595 (23.43)	15.5	5.2	DLIFMXBXK1555	34	7.4	DLIFMXBXL0346
685 (26.97)	18.3	5.1	DLIFMXBXK1835	41	7.1	DLIFMXBXL0416
770 (30.31)	21.5	5.1	DLIFMXBXK2155	47	6.9	DLIFMXBXL0476

Height millimeters (inches)	$V_n = 36000V$ Terminal Type C Base 695x185 (Length x Width)			$V_n = 42000V$ Terminal Type C Base 520x185 (Length x Width)		
	C (μF)	R_s (m Ω)	Part Number	C (μF)	R_s (m Ω)	Part Number
315 (12.40)	9	13.5	DLIFMXCXM0905	3.5	5.5	DLIFMXCXN0355
410 (16.14)	14.2	10.5	DLIFMXCXM1425	5.6	8	DLIFMXCXN0565
500 (19.69)	19.3	9.3	DLIFMXCXM1935	7.7	7.2	DLIFMXCXN0775
595 (23.43)	24.8	8.6	DLIFMXCXM2485	9.8	6.9	DLIFMXCXN0985
685 (26.97)	30	8.2	DLIFMXCXM0306	12	6.7	DLIFMXCXN0126
770 (30.31)	35.5	7.9	DLIFMXCXM3555	14	6.6	DLIFMXCXN0146

Height millimeters (inches)	$V_n = 56000V$ Terminal Type C Base 695x185 (Length x Width)		
	C (μF)	R_s (m Ω)	Part Number
315 (12.40)	2.6	11.6	DLIFMXCXO0265
410 (16.14)	4.2	9.2	DLIFMXCXO0425
500 (19.69)	5.7	8.3	DLIFMXCXO0575
595 (23.43)	7.3	7.8	DLIFMXCXO0735
685 (26.97)	8.8	7.5	DLIFMXCXO0885
770 (30.31)	10.3	7.4	DLIFMXCXO1035

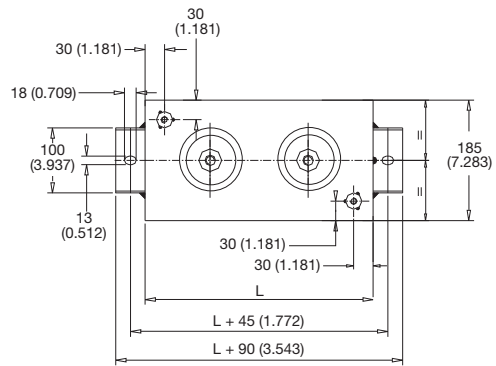
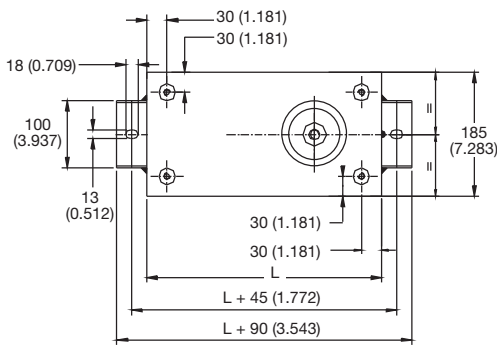
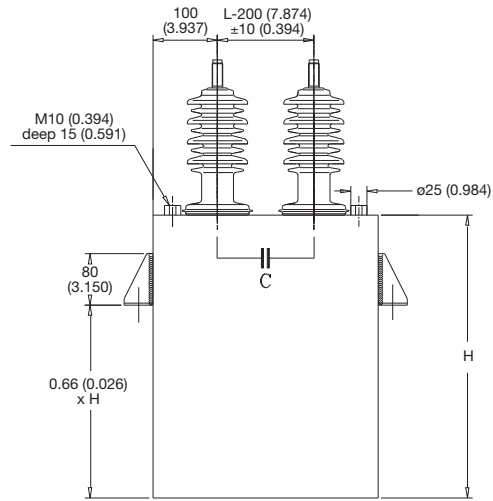
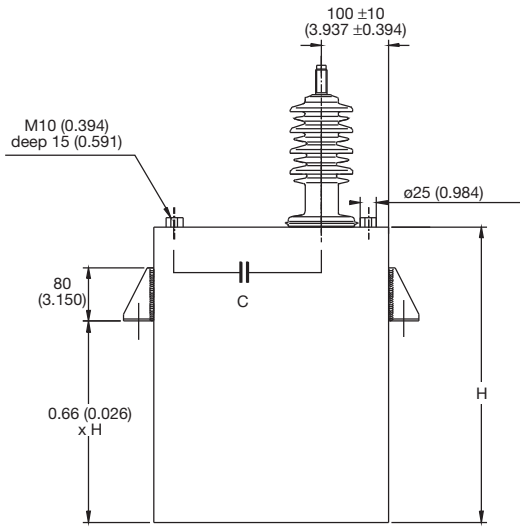

A

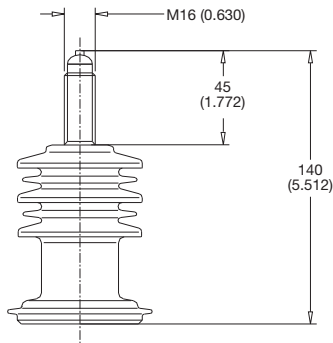

Creepage distance 195 (7.677)
Air distance 93 (3.661)

L_{terminal} = 140nH
Un ≤ 16kV

B

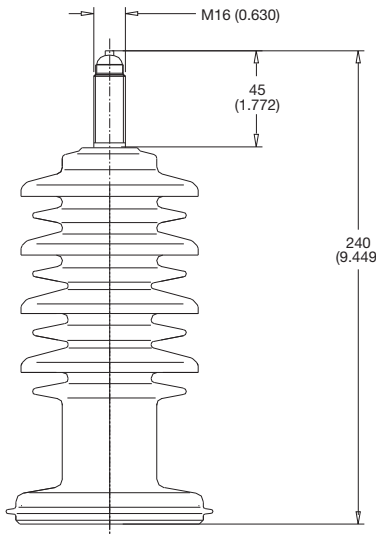

Creepage distance 440 (17.323)
Air distance 191 (7.520)

L_{terminal} = 240nH
16kV < Un ≤ 32kV

C

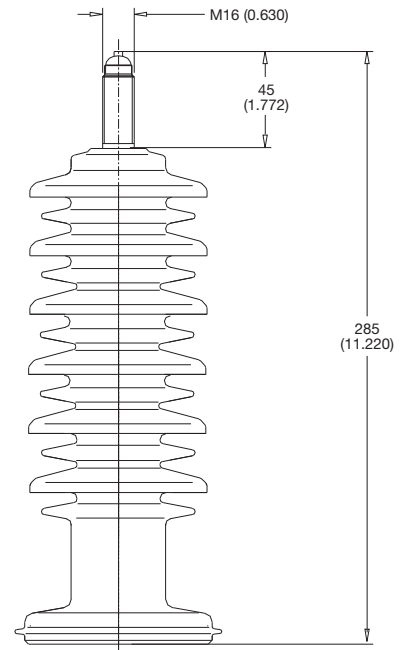

Creepage distance 615 (24.213)
Air distance 239 (9.409)

L_{terminal} = 285nH
32kV < Un ≤ 56kV